

SI-3103(M) 5" Dual Action Sander

SI-3103-6(M) 6" Dual Action Sander

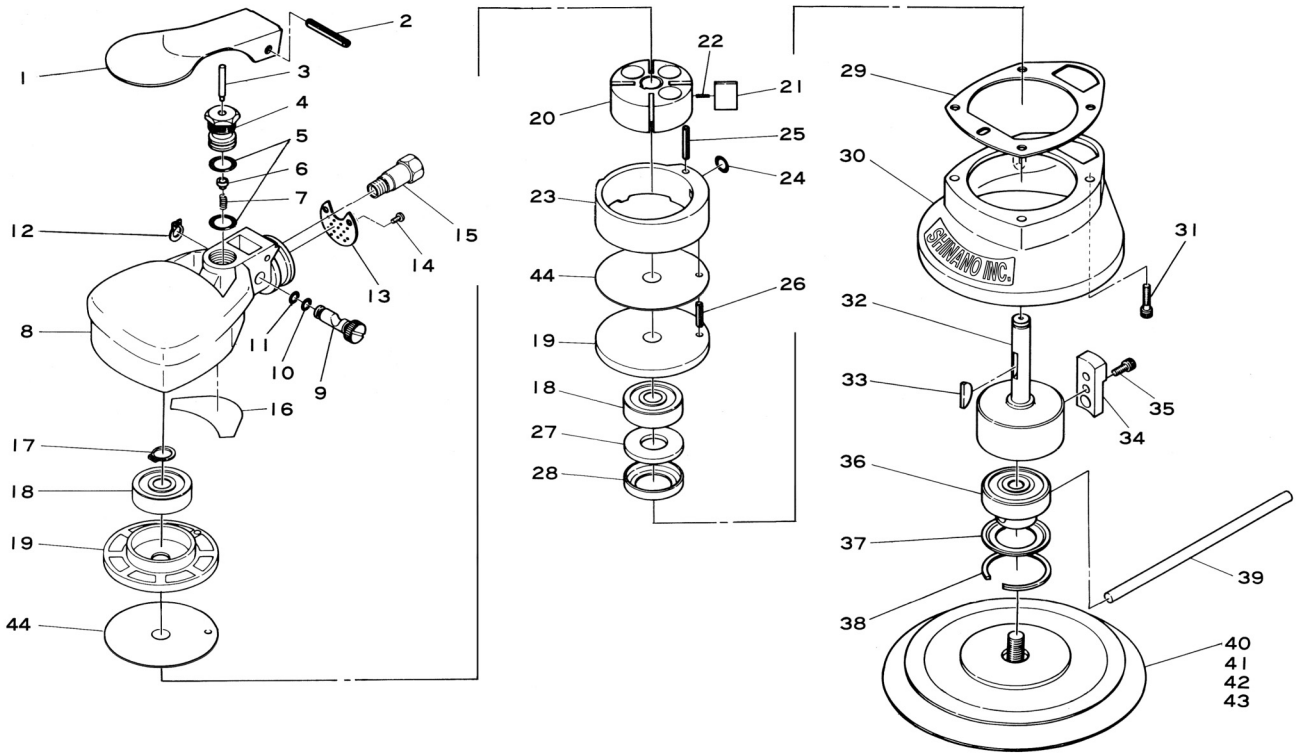

Ref. No.	Parts No.	Description	Q'ty	Ref. No.	Parts No.	Description	Q'ty
1	490-8	Throttle Lever	1	24	P-7	O-Ring	1
2	40-30	Roll Pin (4-30mm)	1	25	25-10	Roll Pin (2.5-10mm)	1
3	455-11	Valve Pin	1	26	25-6	Roll Pin (2.5-6mm)	1
4	490-4	Valve Body	1	27	570-1	Felt Ring	1
5	S-10	O-Ring	2	28	481-9	Seal Cover	1
6	455-21	Valve	1	29	490-13	Motor Gasket	1
7	490-20	Valve Spring	1	30	491-13	Pad Cover	1
8	490-42	Motor Housing	1	31	Z-632-127	Cap Screw	4
9	485-4	Air Regulator	1	32	491-9	Balancer Shaft	1
10	P-5	O-Ring	1	33	480-23	Key	1
11	P-4	O-Ring	1	34	491-38	Adjust Weight	1
12	JS-8	Retaining Ring	1	35	Z-M40-80	Cap Screw	2
13	490-47	Deflector	1	36	491-32	Random Shaft Assy. incl. Ball Bearing & Washer (6202LLUC2,480-12A)	1
14	JIM30-50	Screw	2	37	480-17A	Seal Plate	1
15	460-51	Inlet Bushing	1	38	BR-35	Retaining Ring	1
16	490-54	Seal (Crescent)	1	39	480-54	Bar Wrench (5-100mm)	1
17	JS-10	Retaining Ring	1	40	M-125H	5" Velcro Pad	1
18	6200-ZZ	Ball Bearing	2	41	M-150H	6" Velcro Pad	1
19	490-9A	Bearing Case	2	42	P-125H	5" Leather Pad	1
20	490-5	Rotor	1	43	P-150H	6" Leather Pad	1
21	490-6	Rotor Blade	4	44	490-2A	End Plate	2
22	490-1	Blade Spring	2				
23	490B-36B	Cylinder	1				